

Product data sheet

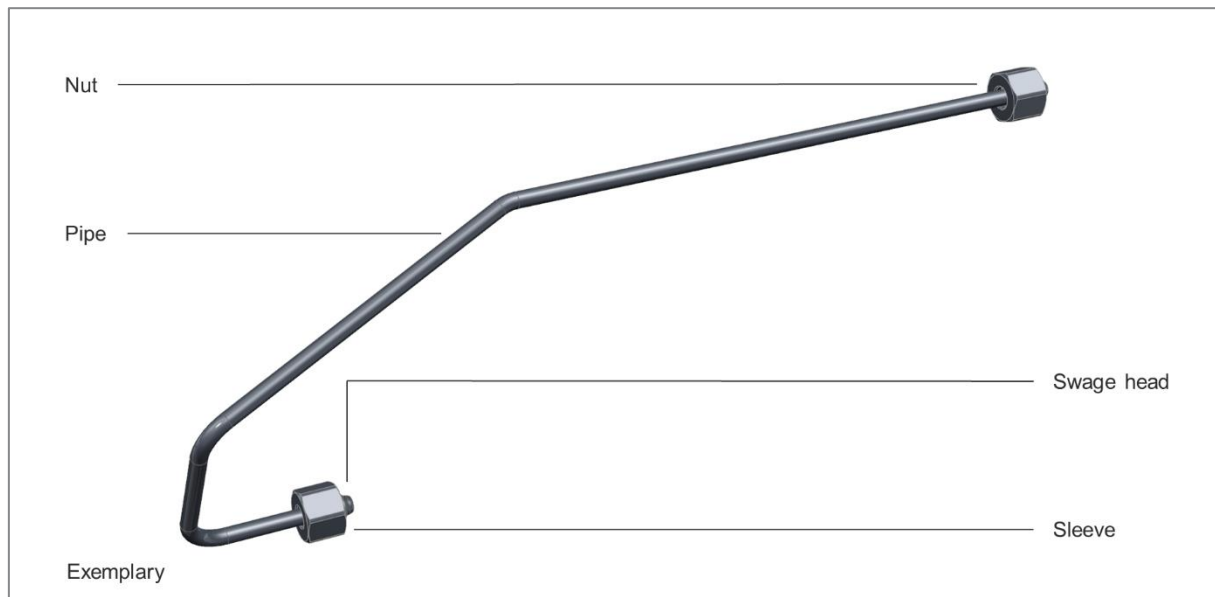

TOPAQ H₂ Pipes (PPH2)

Product specification



P+P's H₂ pipes are used to ensure the safe supply and distribution of hydrogen in mobile and stationary hydrogen applications.

With its certified metallic swage head connection, a reliable re-assembly is guaranteed.

By specifically varying the pipe dimensions, it is possible to meet the customer's specifications and installation space requirements in the best possible way.

Technical features

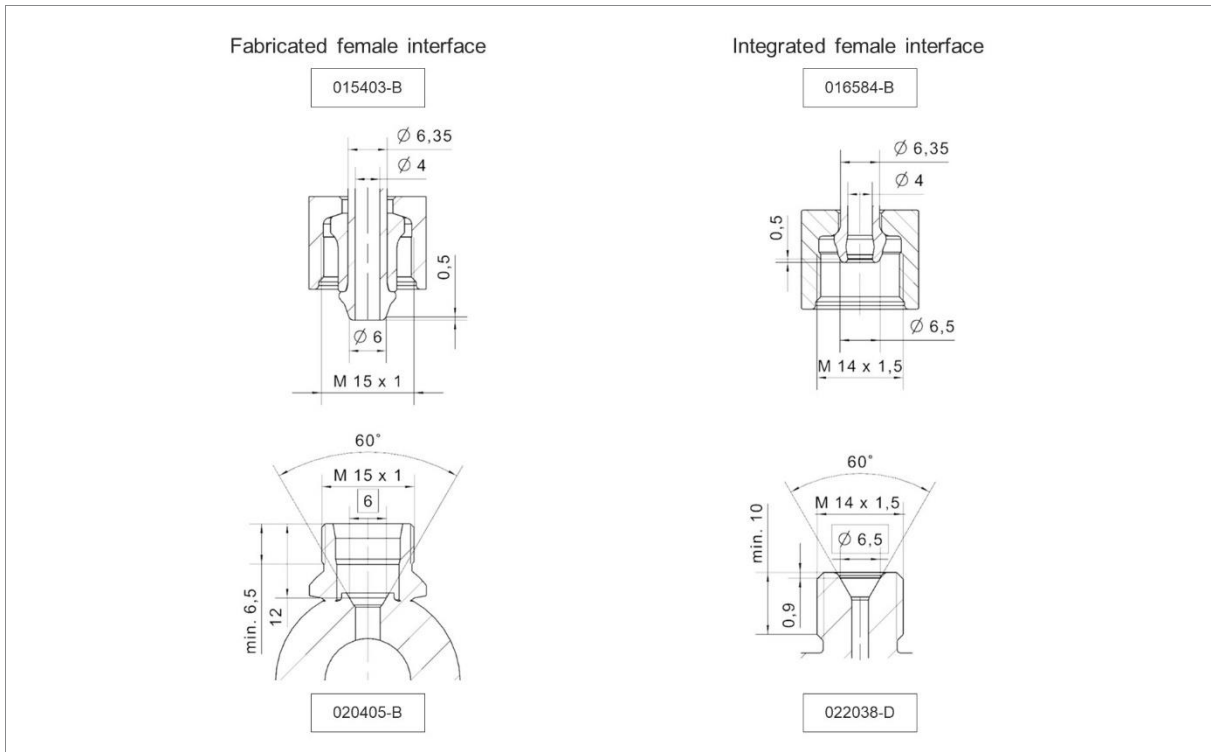

The following variants are currently under validation at P+P:

H ₂ Pipes	
Technical data	
Inner pipe diameter	4 mm
Outer pipe diameter	6.35 mm
Length pipe	max. 1.5 m
Material	PPH2 ¹⁾
Surface protection	Zn, Zn-Ni
Sealing type	Metal-to-metal
Interfaces Thread definitions	
Fabricated female interface (015403-B) e4*79/2009*406/2010*00075*00	M15x1-6H
Integrated female interface (016584-B) e4*79/2009*406/2010*00075*00	M14x1.5-6H
Operating conditions	
Operating temperature	-40 to +85 °C
Nominal working pressure (50.000 cycles)	up to 700 bar
Burst pressure	> 3900 bar
Medium	Hydrogen
Leakage rate	<10 Ncm ³ /h

1) PPH2 is a protected designation of the Poppe + Potthoff Präzisionsstahlrohre GmbH

Technical features

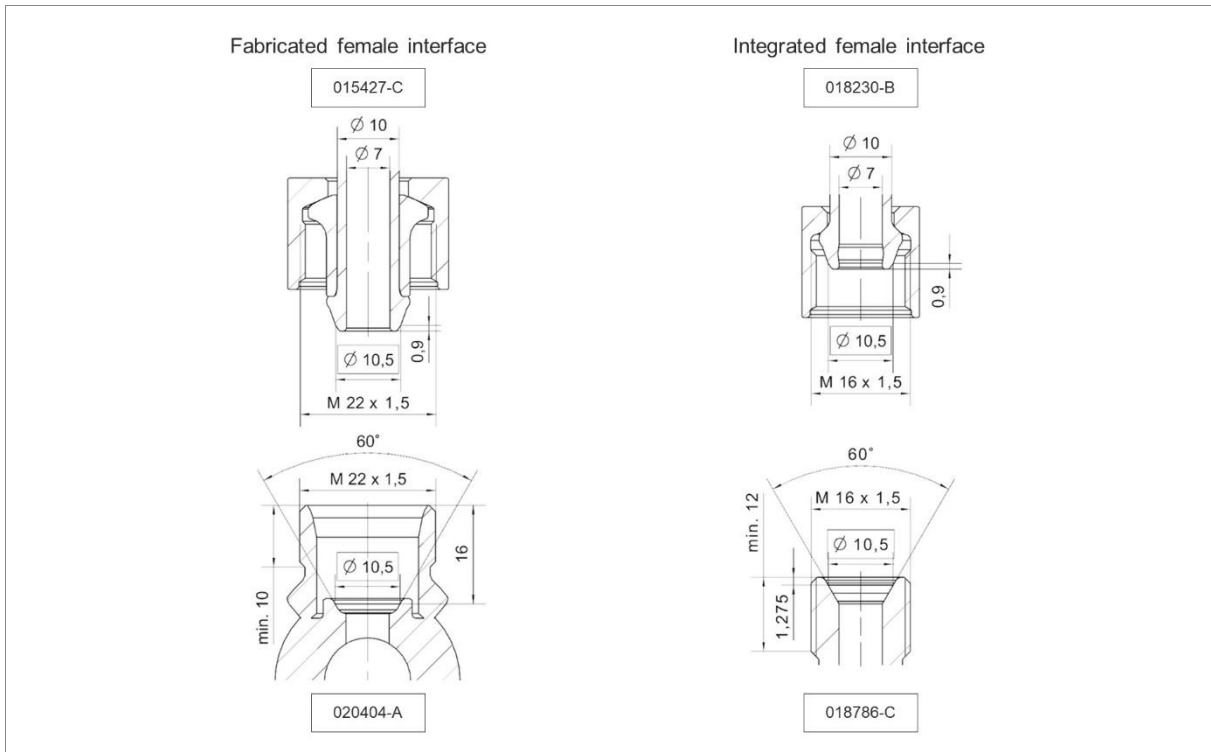

The following variants are currently under validation at P+P:

H ₂ Pipes	
Technical data	
Inner pipe diameter	7 mm
Outer pipe diameter	10 mm
Length pipe	max. 1.5 m
Material	PPH2 ¹⁾
Surface protection	Zn, Zn-Ni
Sealing type	Metal-to-metal
Interfaces Thread definitions	
Fabricated female interface (015427-C) e4*79/2009*406/2010*00077*01	M22x1.5-6H
Integrated female interface (018230-B) e4*79/2009*406/2010*00077*01	M16x1.5-6H
Operating conditions	
Operating temperature	-40 to +85 °C
Nominal working pressure (50.000 cycles)	up to 350 bar
Burst pressure	> 3000 bar
Medium	Hydrogen
Leakage rate	<10 Ncm ³ /h

1) PPH2 is a protected designation of the Poppe + Potthoff Präzisionsstahlrohre GmbH

Technical features

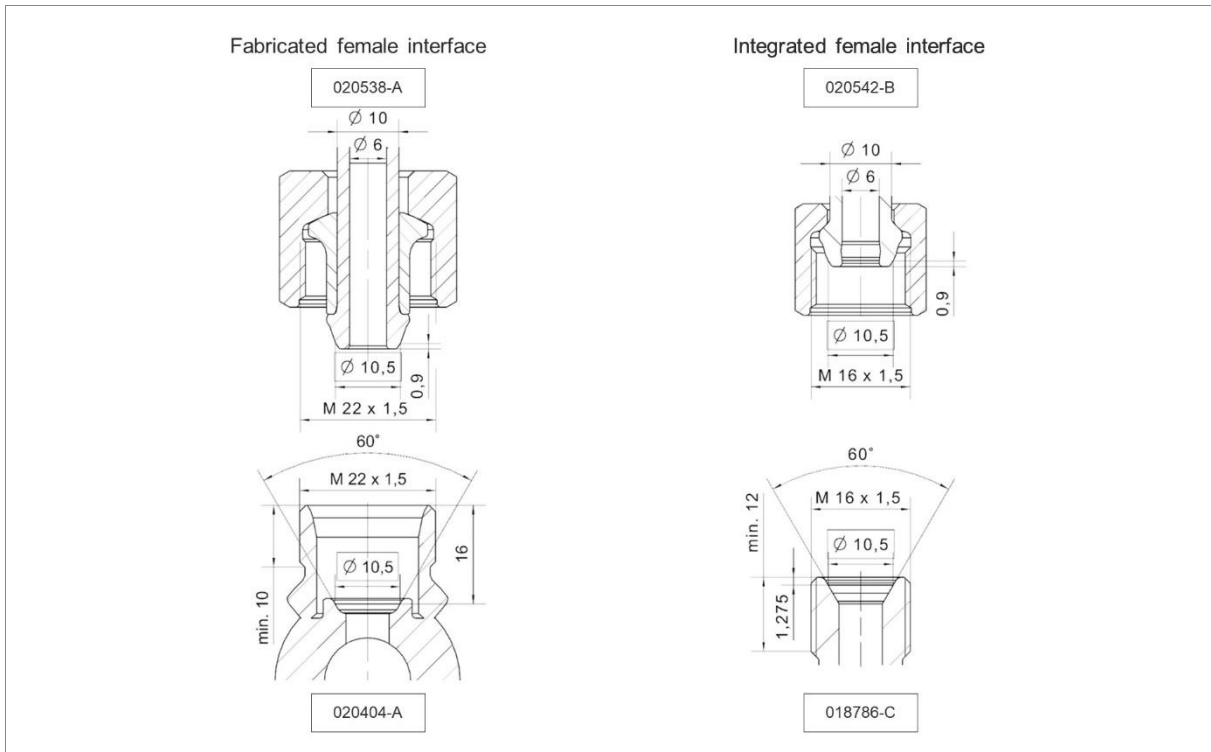

The following variants are currently under validation at P+P:

H ₂ Pipes	
Technical data	
Inner pipe diameter	6 mm
Outer pipe diameter	10 mm
Length pipe	max. 1.5 m
Material	PPH2 ¹⁾
Surface protection	Zn, Zn-Ni
Sealing type	Metal-to-metal
Interfaces Thread definitions	
Fabricated female interface (020538-A)	M22x1.5-6H
Integrated female interface (020542-B)	M16x1.5-6H
Operating conditions	
Operating temperature	-40 to +85 °C
Nominal working pressure (50.000 cycles)	up to 700 bar
Burst pressure	> 4300 bar
Medium	Hydrogen
Leakage rate	<10 Ncm ³ /h

1) PPH2 is a protected designation of the Poppe + Potthoff Präzisionsstahlrohre GmbH

Technical features

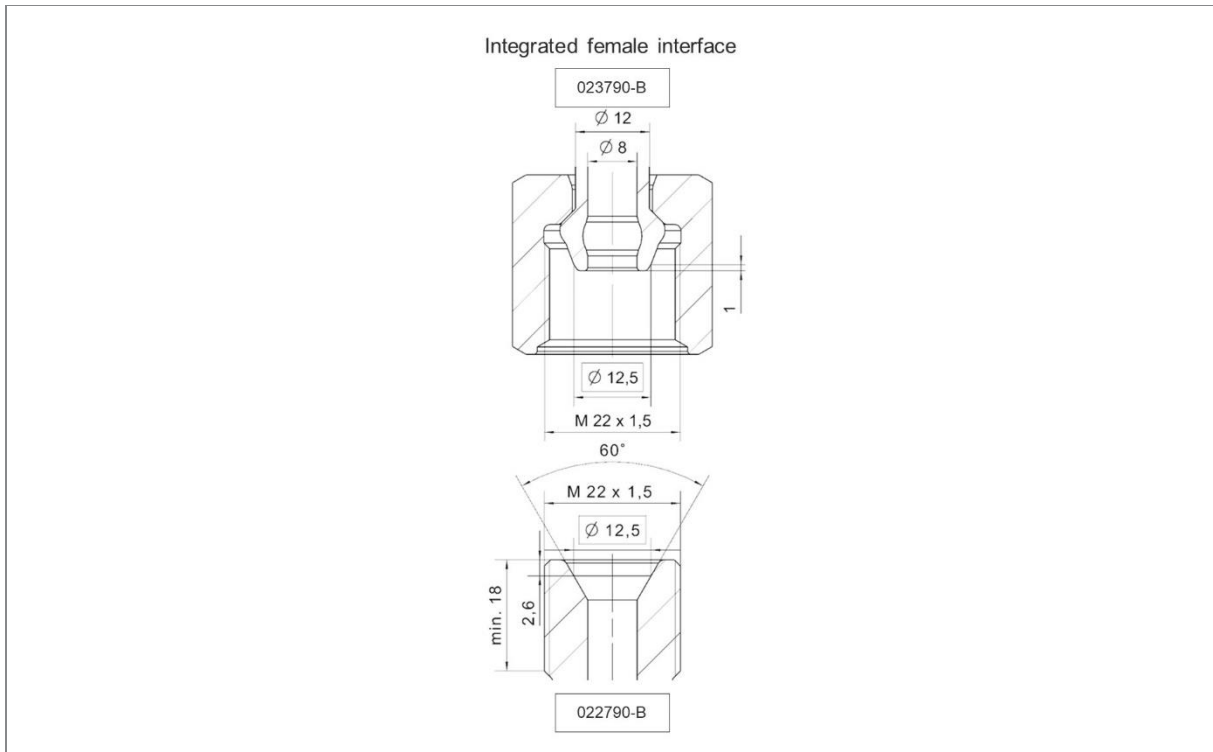

The following variants are currently under validation at P+P:

H ₂ Pipes	
Technical data	
Inner pipe diameter	8 mm
Outer pipe diameter	12 mm
Length pipe	max. 1.5 m
Material	PPH2 ¹⁾
Surface protection	Zn, Zn-Ni
Sealing type	Metal-to-metal
Interfaces Thread definitions	
Integrated female interface (023790-B)	M22x1.5-6H
Operating conditions	
Operating temperature	-40 to +85 °C
Nominal working pressure (50.000 cycles)	up to 700 bar
Burst pressure	> 3450 bar
Medium	Hydrogen
Leakage rate	<10 Ncm ³ /h

1) PPH2 is a protected designation of the Poppe + Potthoff Präzisionsstahlrohre GmbH

Certification & safety information

The product may only be used after installation by qualified personnel according to the corresponding installation guide. Usage for production of commercial goods is only permitted in certified countries. Otherwise, the product may only be used for testing purposes.

NOTE

Only to use with dry hydrogen according to DIN EN 17124 (3.7 or higher). Under all circumstances avoid contact with moist and/or water on the inner surface due to the risk of corrosive effects.

Certificates ²⁾				
Europe				
	6.35x4	10x7	10x6	12x8
EC79/2009, EU406/2010	Certified	Certified	Tests passed	Acc. to ³⁾
UN/ECE R134	n/a ⁴⁾	n/a	n/a	n/a
North America (USA, Canada)				
	6.35x4	10x7	10x6	12x8
HGV 3.1-2022	Tests passed ⁵⁾	Acc. to	Acc. to	Acc. to
SAE J2579:2018	Acc. to	Acc. to	Tests passed ⁶⁾	Acc. to

2) This information applies only to tests and certifications of the base pipe. Fitting-specific information on tests and certifications are given in the previously presented tables for relevant interfaces.

3) Pipe design according to P+P design guidelines, which have been approved by selected and successfully tested pipe dimension in accordance with the referenced standards.

4) UN/ECE R134 does not include specific testing of pipes.

5) HGV 3.1-2022 explicitly mentions only stainless steel pipes. Nevertheless, 6.35x4 PPH2 pipes were successfully tested according to HGV 3.1-2022 chapter 5 & 19.

6) 10x6 PPH2 pipes were successfully tested in hydrogen tests according to SAE J2579:2018, appendix B.

Manufacturer

Poppe + Potthoff GmbH

Dammstraße 17

32824 Werther

Germany

Phone: +49 (0) 5203 91 66 0

Fax: +49 (0) 5203 91 66 100

info@poppe-potthoff.com

www.poppe-potthoff.com



TOPAQ is a Poppe + Potthoff brand